



# PRODUCT MANUAL

## Zebra® LockJaw BGX2

### Warranty

✓ Lifetime warranty

### Installation & Adjustment Instructions

#### INSTALLATION

1. Use Figure 1(a-c) to determine the configuration that will be required.
2. Determine the correct hole pattern using Figure 2.
3. Mount the skimmer to the lockjaw using the hardware included.

#### ADJUSTMENT

1. Close the clamp lever (Figure 3).
2. Loosen both locknuts.
3. Adjust the rubber grips to the wall thickness of the tank or drum.
4. Tighten both locknuts.

**If you have any questions or require product support, please contact 888-249-4855**

**Fig.1a:** B-Series with Diverter™ and Lockjaw

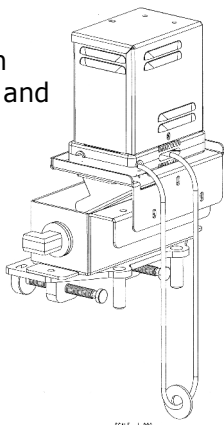

**Fig.1b:** B-Series with Lockjaw

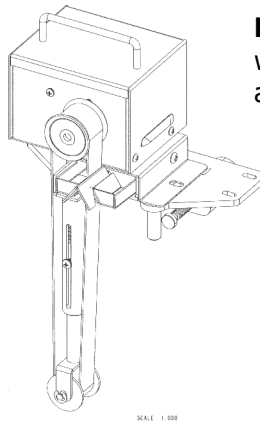

**Fig.1c:** ZVA with Diverter™ and Lockjaw

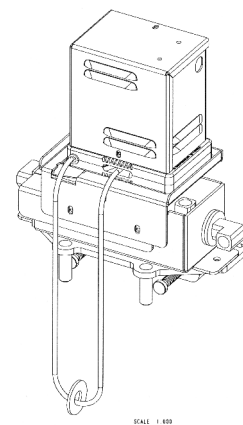

**Fig.2:** Mounting Holes

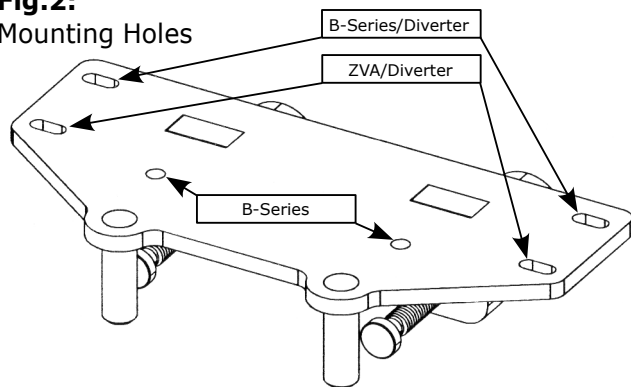

**Fig.3:** Adjustments

