

Zebra[®] Belt Skimmer Manual

Assembly Instructions

1. Remove the belt skimmer components from the main packaging.

(Fixed Lower Pulley Models Only)

2. Unscrew the 10/32 screw (A) from the lower pulley assembly (B).
3. Insert the lower pulley shaft into the shaft base (C), then insert the 10/32 screw through the slot. Do not over tighten this screw-the shaft must be able to slide.
4. Remove the belt and wiper set from its packaging.
5. Wrap the belt (D) over both pulleys. Care **MUST** be taken with stainless steel belts to prevent hairline edge fracture.
6. Place the wipers (E), one on each side of belt, into the collection tray (the notch in the wiper should be towards you and pointing downward).
7. Screw the oil discharge hose (not shown) into the fitting on rear side of collection tray. Do not over-tighten.

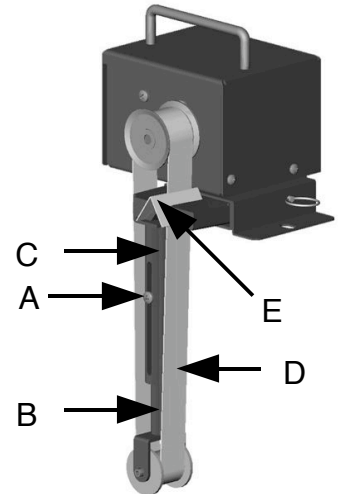

Installation Instructions

1. Mount the belt skimmer to your tank top. Hardware is not provided due to various mounting requirements. NOTE: If using the Diverter™, mount the skimmer to the Diverter, then the Diverter to your tank top. Reference the Diverter manual for more information.
2. Refer to the motor label for motor configuration information, then plug the unit into the appropriate outlet. NOTE: Motor life increases when skimmer is used just the required few hours per day.

Maintenance Instructions

- Clean debris from scrapers, as needed, to prevent their excessive wear.
- Clean debris from belt, as needed, to prevent its excessive wear. Should your belting not lift the surface layer of the fluid being skimmed, please contact us for information regarding biofilm or materials that may cause belt coating.
- Clean debris from the oil collection tray, as needed. Remove scrapers, ring pin, then tray. Clean tray, then replace components in reverse order.

Warnings

- For lifting oil from water-based fluids only
- Maximum belt temperatures: Polyurethane to 80°F (27 °C) and stainless steel
- Do not immerse motor in liquid; shield from spray or vapor
- Do not use in explosive environments
- Per NEC regulations, a ground fault circuit interrupt (GFCI) must be installed

Motor Specifications (referencing motor label)

- 115v, 60Hz, .74 LRA, 85w, .114HP, 28rpm, fan-cooled
- 220v, 50Hz, .23 LRA, 50w, .067HP, 23rpm, fan-cooled
- 24v DC, .19 LRA, 4.56w, .006HP, 8.5rpm

Warranty

- Lifetime on scrapers
- One year all other parts (steel belts 30 days only)

