

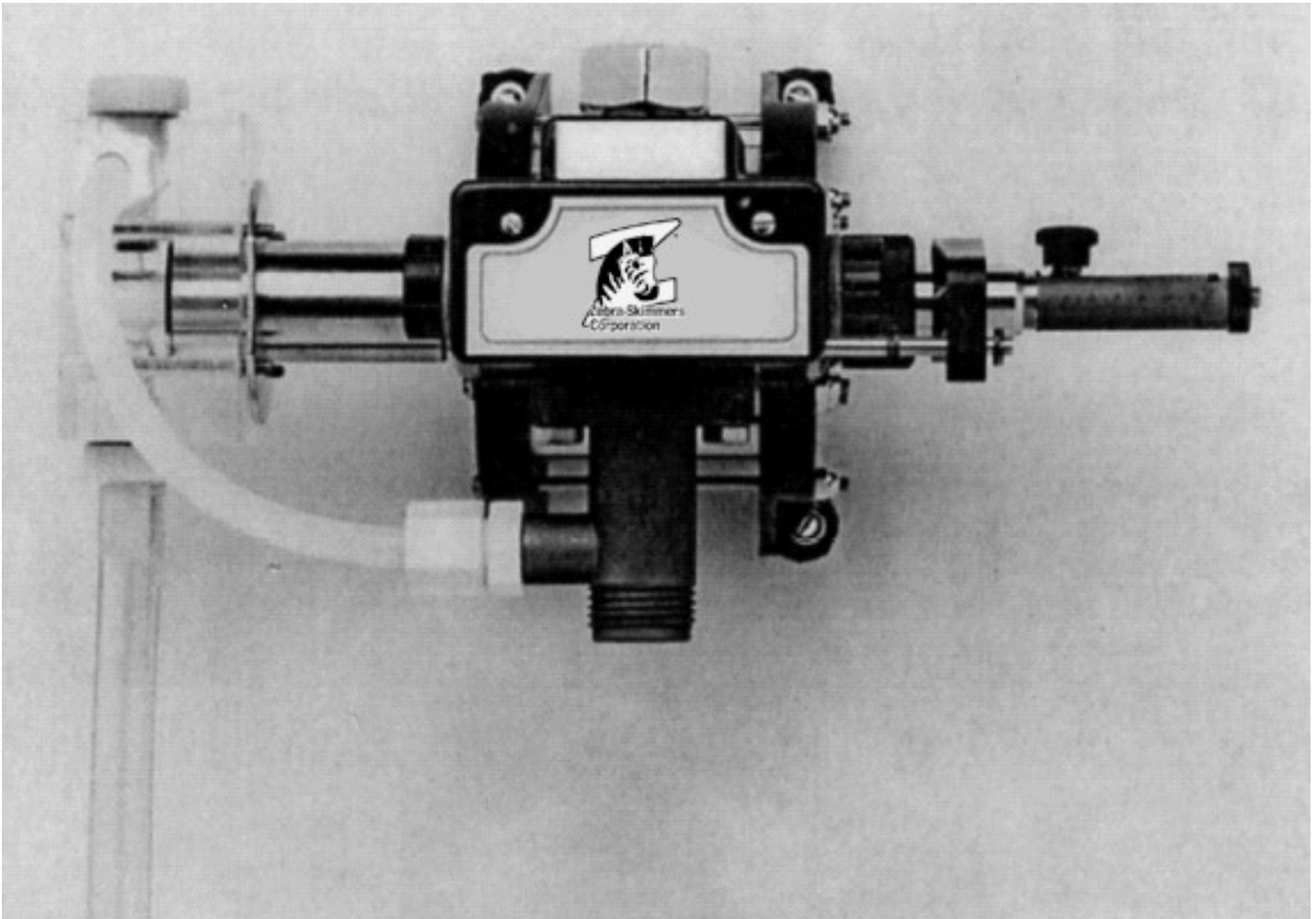

P R O D U C T M A N U A L

Zebra® Proportioning Pump MIXPP Series



Zebra Skimmers Corporation
PO Box 833 Chagrin Fall, OH 44022 USA
www.ZebraSkimmers.com
www.CoolantMaintenance.com
Phone: 1-440-349-0141
Toll Free: 1-888-249-4855
Fax: 1-440-349-1211

© January 12, 2012 Zebra Skimmers Corp. All rights reserved.

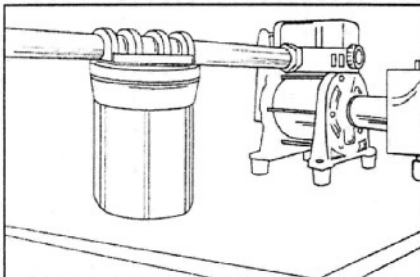
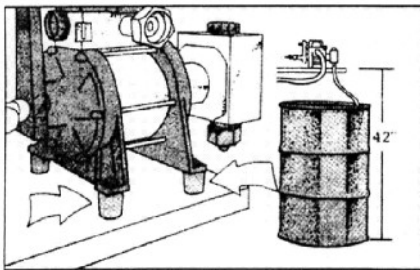
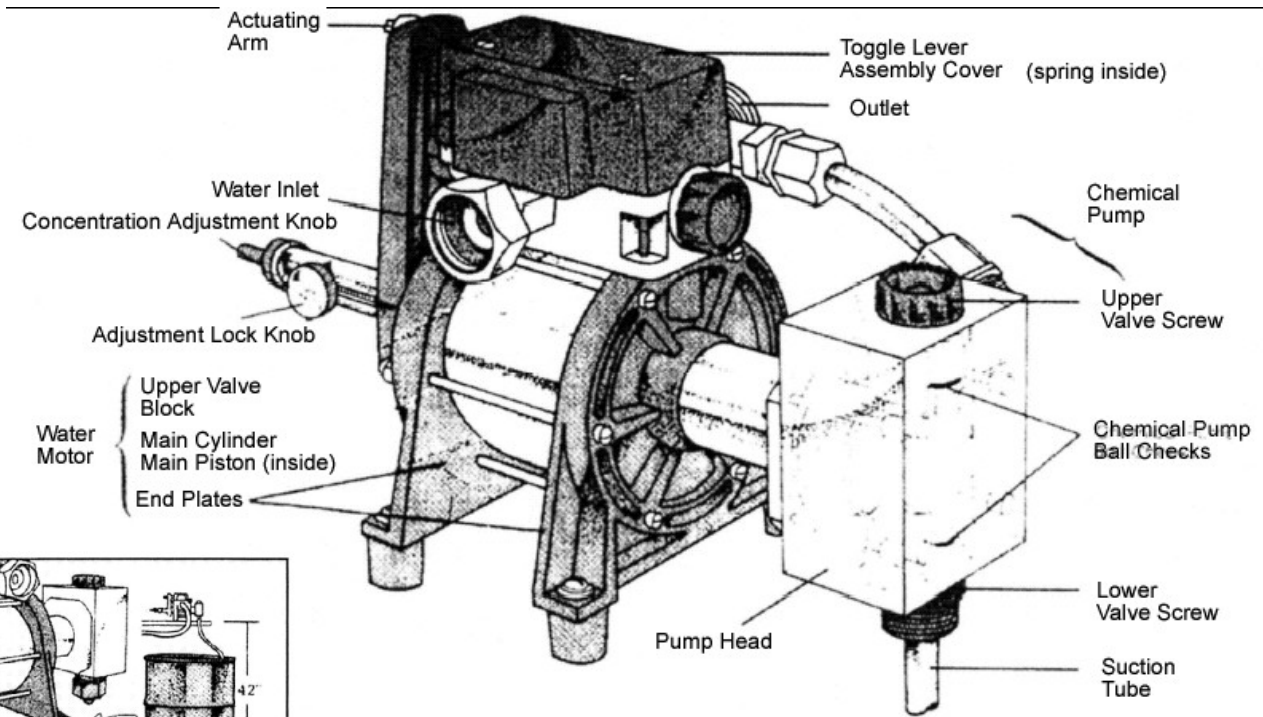

Part #MIXPPX75



The proportioner must be installed in compliance with all local plumbing codes. The proportioner water feed line must be isolated because chemical back flow through the proportioner is possible. An approved back flow preventer must be installed upstream from the proportioner to prevent possible chemical contamination of the water supply.

PROPORTIONING PUMP INSTALLATION

1. Mount the proportioner on a bracket or shelf (for horizontally-configured models) or to the wall directly (for vertically-configured models) using the four rubber feet provided. Mount the pump high enough to allow for your concentration container to be placed directly below the intake hose.
2. Install a 20 micron water filter on the inlet water line of the proportioner to prevent damage to pump components. Failure to filter the water supply will void the warranty.
3. Install a water limiter on the inlet water line (if the inlet water pressure can exceed 65 psi) to prevent pump component damage.
 Note: For concentrate viscosities of 500-700 SUS, limit the incoming water to 10-20 psi.
 Note: The proportioner is designed to be used with 3/4" garden hose connections for both the water inlet and outlet. The unit can be connected with rigid pipe, if desired. All necessary hoses and piping for this installation type are not supplied.
4. On the discharge side of the proportioner, connect the line which will feed the mixture to a central reservoir or to mixture use points. If you are using pipe to make these connections, use a 3/4" garden hose NPT adapter. Note: If installing a pipe for vertical delivery to above-plant conduit, install a check valve on the outlet side of the pump to prevent fluid from re-entering pump. Any above-plant, horizontal conduit should be installed with a 1" slope, also to prevent back pressure.
5. Attach the suction tube to the chemical pump and place the bottom end of the tube into the product container. Note: A 6' long intake hose is provided. You may use any hose with the same ID as the one provided with a max length of 15'. The intake hose may have slight bend only.

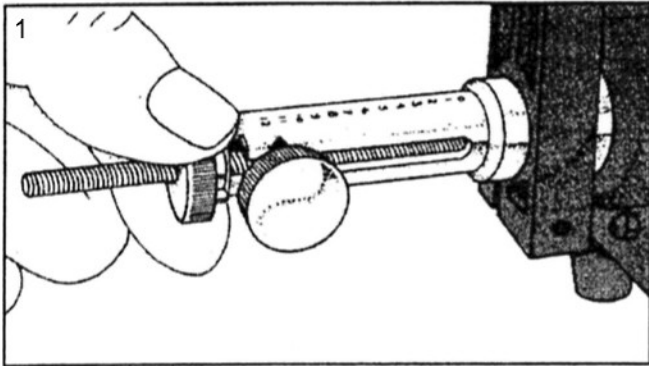

PUMP START-UP

1. Loosen the adjustment locking knob and turn the concentration adjustment knob to the maximum setting (Position 10).
2. Check all connections and fittings for proper tightness and turn on the water to the pump. Note: The plastic fittings on the proportioner only need to be tightened by hand for proper sealing.
3. As water flows through the water motor of the pump, the actuating arm and piston at the rear of the proportioner will move back and forth. This shaft operates the chemical pump piston. The concentrate will start rising up the suction tube.
4. Once the product leaving the chemical pump reaches the main water stream, a sample can be taken of the mixture for a concentration test. Note: This sample should be from a collection of mixture, as in a bucket or cup, as shown, and not directly from liquid flowing from pump. If using a refractometer for concentration measurement, verify how your fluid will read on the Brix scale via the product information for your concentrate.

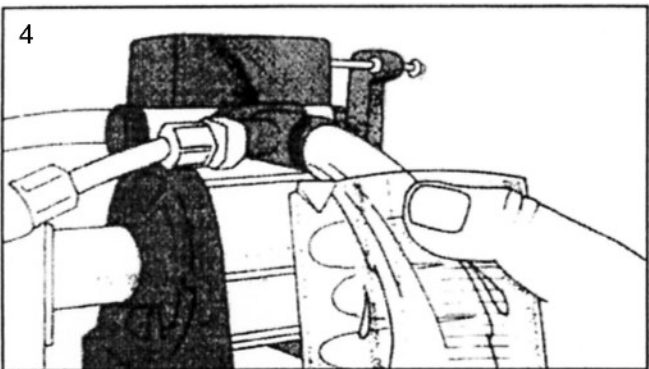
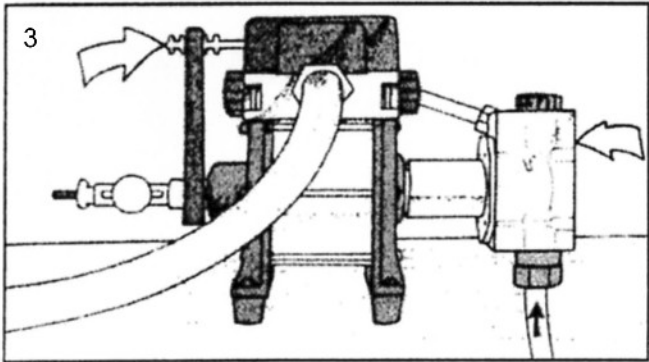

You may then adjust the concentration adjustment knob, as needed, to give the desired product-to-water ratio.
 Note: The numbers on the graduated scale are reference marks only and do not represent any particular ratio. The #10 is the strongest concentration and the #0 is the weakest. When the proper ratio is reached, tighten the adjustment locking knob (finger tight is sufficient).

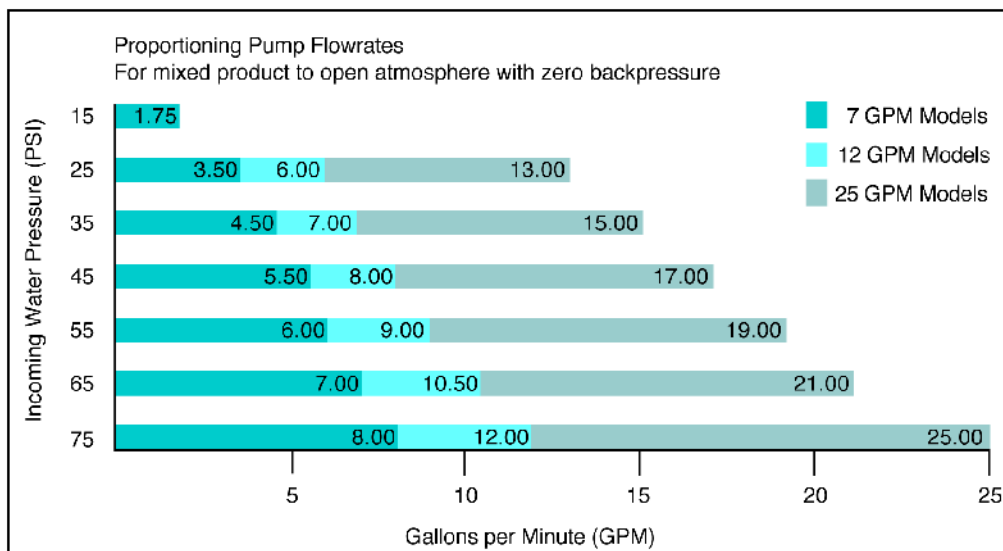

TROUBLESHOOTING

Problems:

1. Water motor will not run.

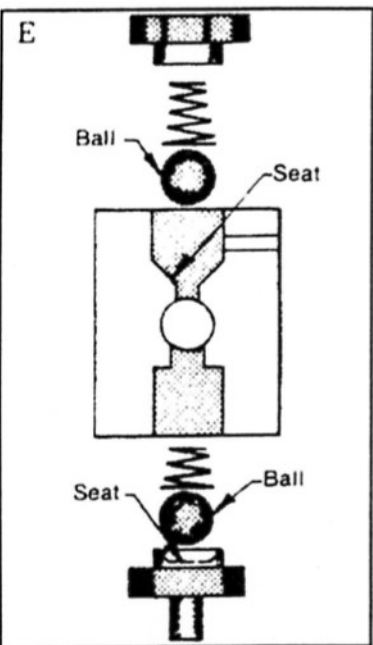
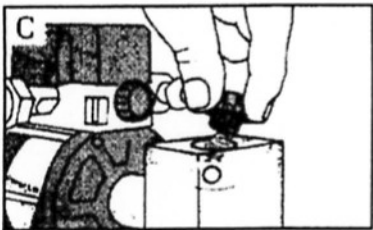
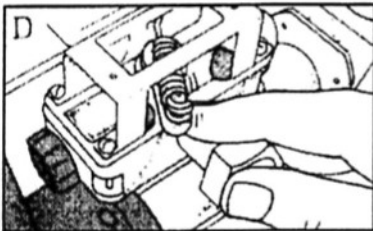
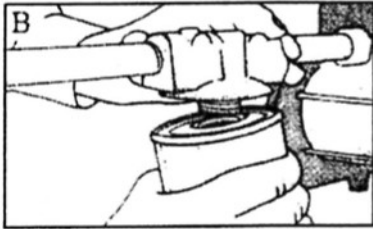

Causes:

- Water turned off to unit.
- Water filter clogged.
- Discharge lines shut off or clogged.
- Proportioner stalled; proportioner operates Intermittently - then stalls.
- Weak or broken toggle lever spring.
- Actuating arm out of adjustment.

- Water motor not working.
- Proportioner concentrate adjustment set on minimum.
- Pump head seals dry.
- Upper or lower valve screws sucking air.
- Foreign material on ball seat. Concentrate has caused balls to stick.
- Excessive discharge back pressure.

Solutions:

- Turn water on to unit.
- Replace filter element.
- Check to be sure lines are clear and all system valves are open.
- Water inlet pressure has dropped. Relieve downstream back pressure; if unit restarts, there is no problem. If unit does not restart, the valve block may need to be rebuilt.
- Replace spring.
- Relocate actuating arm to .400" from back of chrome shaft.

- Check motor per Item 1 above, A through F.
- Re-adjust. Set on 10 to prime.
- Remove top valve screw, flood cavity with water. Replace spring and valve screw carefully. Start unit.
- Tighten fittings - hand tighten only.
- Remove valve balls carefully, flush and clean valve seats and balls, replace balls, springs and valve screws.
- Relieve downstream back pressure until unit is primed.

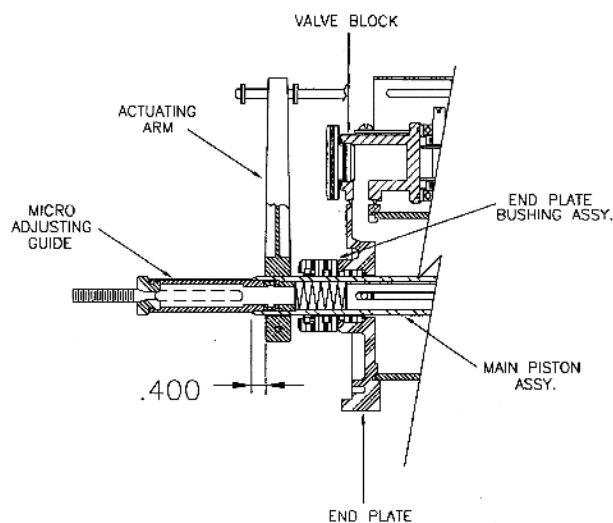

DATE	REV	BY	CHK
10/5	1/1	1/19/01	ZYS
DESIGN	ILL	DATE	APP'D
FF	FF	FF	FF
REVISION	DATE	BY	CHK

EXPLODED VIEW

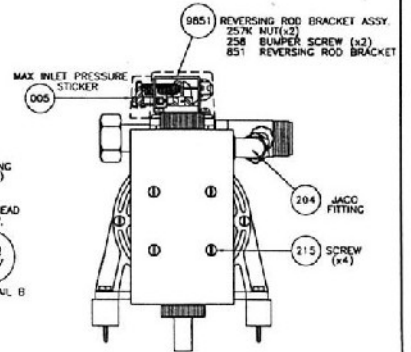
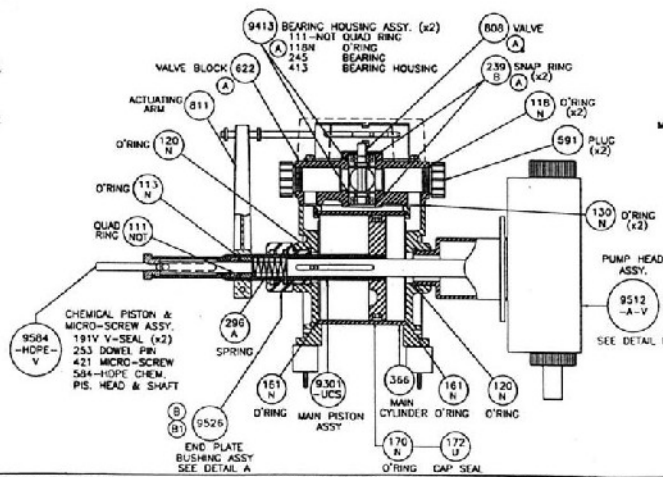
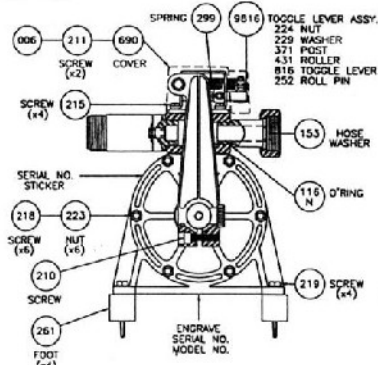
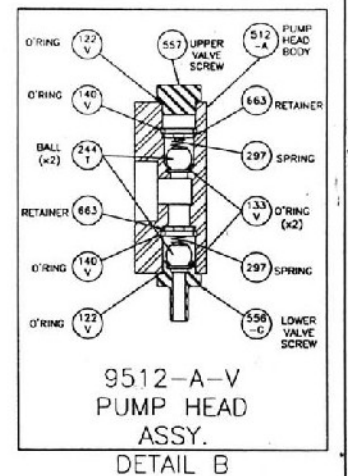
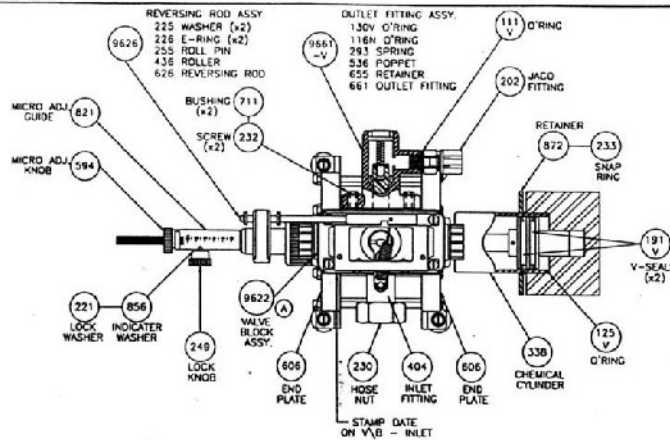
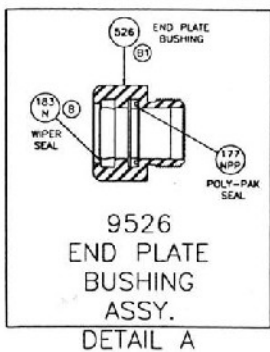

REVISION:
 (A) UPDROVED FROM 8000 SERIES TO 8000 SERIES 01/23/01.
 (B) WAS 178M DOUBLE LP WIPER 03/25/02.
 (C) WIPER SEAL GROOVE DIA. CHANGE 03/25/02.

SHIPPING INFORMATION:
 LARGE BOX = 001-2
 TOP INSERT = 001-2A
 MIDDLE INSERT = 001-2B
 BOTTOM INSERT = 001-2C

TUBE WEIGHT NO. = 402-500
 SUCTION TUBE NO. = 267
 OPERATING MANUAL REQUIRED
 PUMP SCHEMATIC REQUIRED

MODEL NO. SERIAL NO. STICKER
 LOWER LEFT HAND CORNER OF BOX

SCALE:	SHEET:	DATE:
NTS	1:1	10/30/00
DRAWN BY:	CHECKED BY:	
RLM	DK	
SERIES:	DESC:	
7 GPM	1Boz. PUMP	
REVISION:	REVISED BY:	DATE:
B1	SC	03/21/05



Zebra Skimmers Corp.
 27000 Richmond Road
 Solon, OH 44159

ST. NO. MIXPP518